

MFS-600-U series

600W Constant Voltage Enclosed Switching Power Supply with PFC function



■ Features:

- Universal AC input / Full range: 80~277VAC or 110~390VDC
 - Built-in active PFC function
- Protections: Over current / Short circuit / Over Voltage / Over temperature
 - Low no load power consumption, high efficiency
 - Base plate with conformal coating
- Wide range of operating temperature range: -40°C to +70°C
 - Remote sense compensation, remote ON/OFF function
 - Built-in 5V/1A standby output



MODEL NUMBERING

MFS	-	600	-	X	-	U
SERIES		RATED OUTPUT POWER		RATED OUTPUT VOLTAGE		INPUT VOLTAGE RANGE
ENCLOSED TYPE SWITCHING POWER SUPPLY, 1U PROFILE, CONSTANT VOLTAGE DESIGN, PFC FUNCTION	-	600 means 600W	-	X = 12	12V	U means 80~277VAC / 110~390VDC
				X = 15	15V	
				X = 24	24V	
				X = 27	27V	
				X = 36	36V	
				X = 48	48V	

ELECTRICAL SPECIFICATION

MODEL	MFS-600-12-U	MFS-600-15-U	MFS-600-24-U	MFS-600-27-U	MFS-600-36-U	MFS-600-48-U
MAIN OUTPUT						
RATED VOLTAGE	12V	15V	24V	27V	36V	48V
ADJUSTABLE VOLTAGE RANGE (MIN.)	11.8V ÷ 12.6V	14.7V ÷ 15.8V	23.5V ÷ 25.2V	26.4V ÷ 28.4V	35.3V ÷ 37.8V	47V ÷ 50.4V
RATED CURRENT	50A	40A	25A	22.3A	16.7A	12.6A
RATED POWER	600W	600W	600W	600W	600W	600W
LINE REGULATION (TYP.)	± 0.3%					
LOAD REGULATION (TYP.)	± 0.5%					
VOLTAGE ACCURACY (TYP.)	± 1%					
RIPPLE & NOISE (MAX.) [2]	150mV _{p-p}	150mV _{p-p}	200mV _{p-p}	200mV _{p-p}	300mV _{p-p}	300mV _{p-p}
HOLD UP TIME (TYP.)	15ms / 230VAC at full load					
EFFICIENCY (TYP.)	92%	92%	94%	94%	94%	94%
MINIMUM LOAD	0%					
CAPACITIVE LOAD (MAX.)	6000μF	6000μF	4000μF	4000μF	2400μF	1600μF
STANDBY VOLTAGE / CURRENT	5V/1A	5V/1A	5V/1A	5V/1A	5V/1A	5V/1A
STANDBY OUTPUT ACCURACY (TYP.)	± 2%	± 2%	± 2%	± 2%	± 2%	± 2%
STANDBY OUTPUT LINE / LOAD REGULATION (TYP.)	± 0.5% / ± 2%	± 0.5% / ± 2%	± 0.5% / ± 2%	± 0.5% / ± 2%	± 0.5% / ± 2%	± 0.5% / ± 2%

- Note:**
1. Under any conditions, the total power of the product should not exceed the 600W rated power and the output current cannot exceed the rated output current.
 2. Standby output: provide 5V/1A independent output, it is recommended to use with the main circuit.

MFS-600-U series

600W Constant Voltage Enclosed Switching Power Supply with PFC function



INPUT

<u>PARAMETER</u>	<u>OPERATING CONDITIONS</u>	<u>MIN.</u>	<u>TYP.</u>	<u>MAX.</u>	<u>UNIT</u>
VOLTAGE RANGE	AC INPUT	80	-	277	VAC
	DC INPUT	110	-	390	VAC
FREQUENCY RANGE		47	-	63	Hz
AC CURRENT	115VAC	-	-	7.5	
	230VAC	-	-	3.5	A
INRUSH CURRENT	115VAC COLD START	-	40	-	
POWER FACTOR	115VAC ROOM TEMPERATURE,	-	0.98	-	-
	230VAC FULL LOAD	-	0.95	-	-
CONTACT LEAKAGE CURRENT	240VAC		< 0.1		mA
NO LOAD POWER CONSUMPTION	ROOM TEMPERATURE, 230VAC, ON/OFF ADD +5V SIGNAL	-	0.5	-	W

PROTECTIONS

OVER CURRENT	Range: 110%-160% rated current Type: auto-recovery
SHORT CIRCUIT	Type: hiccup mode, auto-recovery, recovery time <3s after the short circuit disappear
OVER VOLTAGE	≤ 16.5VDC ≤ 20VDC ≤ 35VDC ≤ 35VDC ≤ 487VDC ≤ 60VDC ≤ 63VDC Type: shut down output voltage. Re-power on to recovery. Auxiliary <7V, hiccup mode, auto-recovery
OVER TEMPERATURE	Type: shut down output voltage, auto-recovery after the temperature drops

WORKING ENVIRONMENT

WORKING TEMPERATURE	-40°C ÷ +70°C (Refer to Temperature Derating Curve)
WORKING HUMIDITY	20 ÷ 90% RH non-condensing
STORAGE TEMPERATURE AND HUMIDITY	-40°C ÷ 85°C, 10 ÷ 95% RH non-condensing

SAFETY REGULATIONS

<u>PARAMETER</u>	<u>MIN.</u>	<u>TYP.</u>	<u>MAX.</u>	<u>UNIT</u>	<u>CONDITIONS</u>
WITHSTAND VOLTAGE	IN/OUT	4000	-	-	
	IN/GND	1500	-	-	VAC <5mA, 1min
	OUT/GND	1500	-	-	
ISOLATION RESISTANCE	IN/OUT	50	-	-	Environment temperature: 25±5°C
	IN/GND	50	-	-	Relative humidity: <95% RH, non-condensing
	OUT/GND	50	-	-	Testing voltage: 500VDC
SAFETY STANDARDS	Compliance to EN62368-1, designed to meet EN61558-1, EN61558-2-16, EN60335-1				

MFS-600-U series

600W Constant Voltage Enclosed Switching Power Supply with PFC function



EMC REGULATIONS

EMISSIONS	CE	CISPR32/EN55032 Class B		
	RE	CISPR32/EN55032 Class B		
	HARMONIC CURRENT	EN61000-6-2 Class A and Class D		
	FLICKER	EN61000-3-3		
IMMUNITY	ESD	EN61000-4-2	Contact ±8kV / Air ±15kV	Perf. Criteria A
	RS	EN61000-4-3	10V/m	Perf. Criteria A
	EFT	EN61000-4-4	±4kV	Perf. Criteria A
	SURGE	EN61000-4-5	Line to line ±2kV / Line to ground ±4kV	Perf. Criteria A
	CS	EN61000-4-6	10Vrms	Perf. Criteria A
	VOLTAGE DIPS, SHORT INTERRUPTIONS AND VOLTAGE VARIATIONS	EN61000-4-11	0%, 70%	Perf. Criteria B

OTHERS

MTBF (MIN.)	300 000h / 25°C per MIL-HDBK-217F
DIMENSIONS AND CASE MATERIAL	101.6 x 203.1 x 40.5mm (L x W x H); Metal (AL1100, SGCC)
NET WEIGHT	1.0kg
COOLING METHOD	Forced cooling

1. All parameters NOT specially mentioned are measured at 230VAC input, rated load, 25°C of ambient temperature and humidity <75% RH.
2. The output voltage can be adjusted by the ADJ, clockwise to increase.
3. Ripple & noise is measured at 20MHz of bandwidth by using a 12" twisted pair-wire terminated with a 0.1µF i 47µF parallel capacitor.
4. In order to improve the efficiency at high input voltage, there will be audible noise generated, but it does not affect product performance and reliability.
5. Case needs to be connected to the earth (⊕) of the system when the terminal equipment in operating.
6. The room temperature derating of 5°C / 1000m is needed for operating altitude greater than 2000m.
7. Power supply is considered as component not intended to apply by end-user. Power supply meets safety and EMC standards however the final equipment with power supply must be re-quality to comply with EMC Directives.

DERATING CURVE

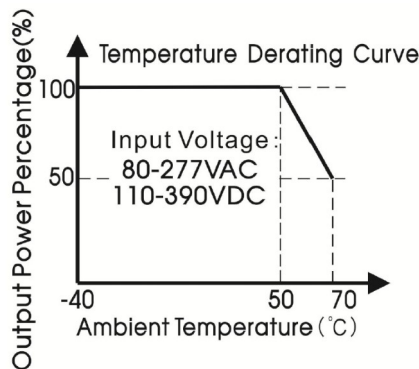

STATIC CHARACTERISTIC

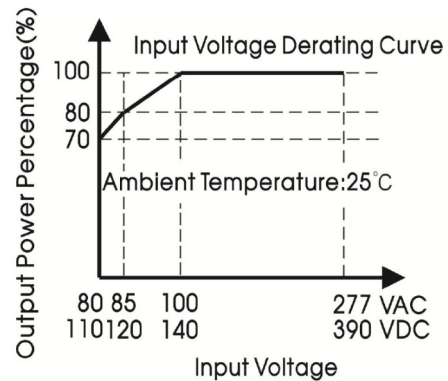

MFS-600-U series

600W Constant Voltage Enclosed Switching Power Supply with PFC function



EFFICIENCY vs INPUT VOLTAGE CURVE

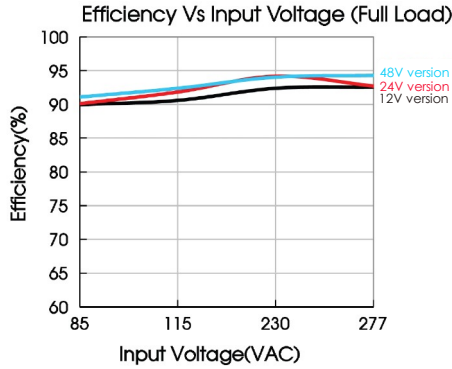

EFFICIENCY vs LOAD CURVE

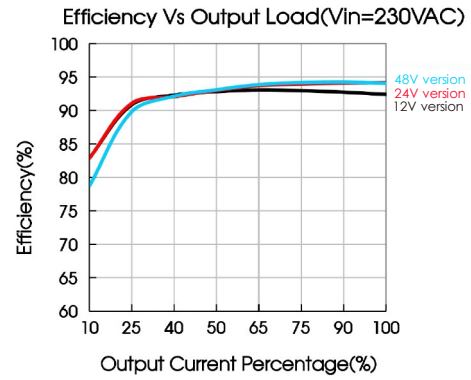

MECHANICAL SPECIFICATION

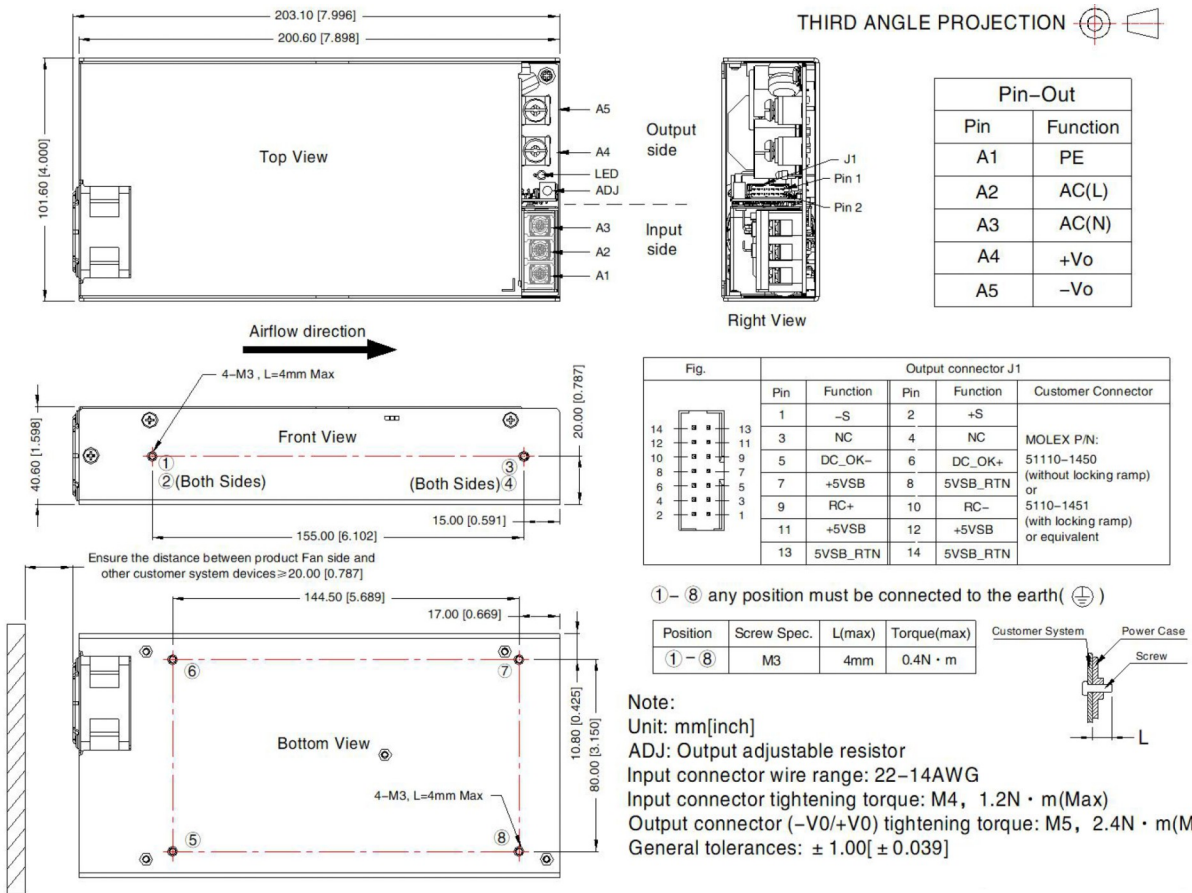

MFS-600-U series

600W Constant Voltage Enclosed Switching Power Supply with PFC function



TYPICAL APPLICATION

1. Remote ON/OFF

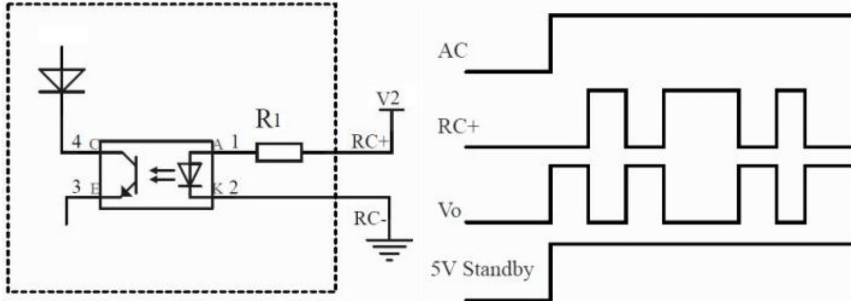

R1 (Product inside)	$2K\Omega, \frac{1}{12} W$
V2 (User side)	5V-15V

- Note:**
- When the product is working normally, apply voltage (5-15V) to RC+ and RC- to trigger the remote ON/OFF function and the output voltage will be off. Withdraw the voltage, the output will be re-established.
 - 5V standby output is not controlled by remote ON/OFF function.

2. DC_OK

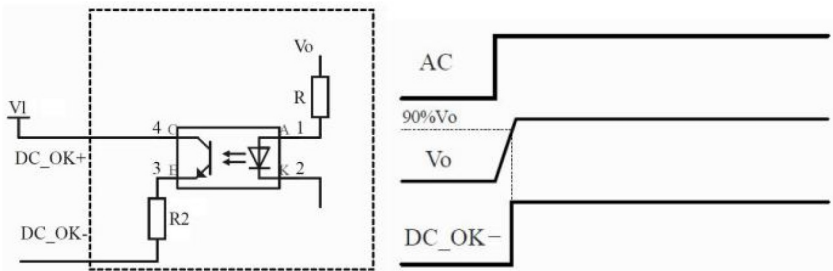

R2 (Product inside)	$1K\Omega, \frac{1}{12} W$
V1 (User side)	5V-15V

- Note:**
- When the output voltage of the product reaches 90% the rated value, DC OK+ will be connected to DC_OK-
 - It's recommended that users apply a certain voltage between DC_OK+ and DC_OK- to detect the signal.

3. Remote Sense Compensation

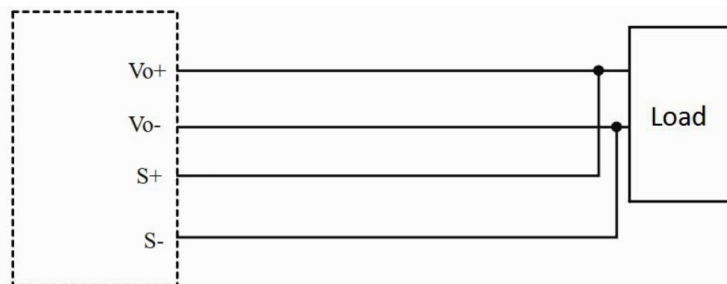

- Note:**
- The left side represents the internal schematic diagram of the product, the right side represents the customer system.
 - Twisted pair wires are needed to S+/S-